



司南导航

Product Specification / 产品规范

K706 OEM Board

K706 OEM 板卡

2017-02-23

REVISION HISTORY / 修订历史

REVISION / 版本	MODIFICATION / 更改	DATE / 日期
1.0	New Release / 新发	2017-02-23

TABLE OF CONTENTS

I. Introduction / 简介	1
II. Specification of K706 OEM Board / K706 OEM 板卡技术规范	1
III. Dimension / 尺寸	4
IV. Pin Arrangement and Definition / 引脚标识和定义	5
V. Application Connection Example / 应用连接示例.....	10

FIGURE & TABLE 图表

Figure 1. K706 Dimension View	5
Figure 2. LAN8720 Connection Diagram	10
Figure 3. K706 Pin Assignment Schematic.....	11
Figure 4. Connections between RS232 COM1, 2, 3 of K706 and Some Other Devices with an UART	12
Figure 5. USB Connection	12
Figure 6. Network Connection.....	12
Figure 7. RJ45 Schematic	13
Table 1. K706 Specification.....	1
Table 2. Pin Definition of K706 24-Pin Connector	5

I. INTRODUCTION / 简介

ComNav K706 is a high precision positioning GNSS multi-system OEM board based on a self-developed ASIC baseband chip (SNB1008). It has small size, low power consumption, light weight, as well as 8GB storage. The K706 tracks GNSS constellations including GPS, BDS, GLONASS and QZSS, it can software upgradable to track Galileo or BDS global signal.

上海司南 K706 OEM 板卡是一款基于自主研发的 ASIC 基带芯片（SNB1008）的 GNSS 多系统高精度定位板卡，尺寸小、功耗低、重量轻，具备 8GB 存储。目前支持 GPS, BDS, GLONASS 和 QZSS。后续可以升级 Galileo 或北斗全球信号。

II. SPECIFICATION OF K706 OEM BOARD / K706 OEM 板卡技术规范

Following table presents the detailed specification of ComNav K706 OEM board. Specific technical characteristics are listed with its physical interface and electrical parameters.

下表中为司南 K706 OEM 板卡的详细规范。同时，还列出了该板卡的各项技术性能，以及它的物理接口和电气接口参数。

Table 1. K706 Specification

K706 SPECIFICATION/ K706 规范			
GNSS Signals GNSS 信号	Positioning 定位	GPS L1, L2	14 GPS satellite tracked at the same time 可同时跟踪 14 颗 GPS 卫星
		BDS B1, B2	14 BDS satellite tracked at the same time 可同时跟踪 14 颗 BDS 卫星
		GLONASS G1, G2	14 GLONASS satellites tracked at the same time 可同时跟踪 14 颗 GLONASS 卫星
		SBAS L1C/A	4 SBAS satellites tracked at the same time 可同时跟踪 4 颗 SBAS 卫星
Time to First Fix 首次定位时间	Cold Start 冷启动		< 50s
	Warm Start 温启动		< 30s
	Hot Start (with RTC)		< 15s

©2017, ComNav Technology Ltd. All rights reserved. SinoGNSS is the trade mark of ComNav Technology Ltd., registered in People's Republic of China. All other trademarks are the property of their respective owners.

K706 SPECIFICATION/ K706 规范		
	热启动（使用 RTC）	
Reacquisition 信号重捕		< 1.5s (fast mode) （快速） < 3s (normal mode) （普通）
Measurement Precision 测量准确度	Pseudorange Precision 伪距精度	GPS: L1=10cm, L2=10cm BDS: B1=10cm, B2=10cm GLONASS: G1=10cm, G2=10cm
	Carrier Phase Precision 载波相位精度	GPS: L1=0.5mm, L2=1.0mm BDS: B1=0.5mm, B2=0.5mm GLONASS: G1=1.0mm, G2=1.0mm
Accuracy 精度	Time Accuracy 授时精度	20ns
	SPP Accuracy 标准单点定位精度	single-frequency 单频: H≤3m, V≤5m (1σ, PDOP≤4) dual-frequency 双频: H≤1.5m, V≤3m (1σ, PDOP≤4)
	Static Differential Accuracy (Supported by Compass Solution) 静态差分精度 (Compass Solution 软件支持)	H: $\pm(2.5+1\times 10^{-6}\times D)$ mm V: $\pm(5 + 1\times 10^{-6}\times D)$ mm
Attitude Accuracy 测姿精度	Azimuth Accuracy (dual-board) 方位角精度 (双板卡)	(0.2/R)°, R is baseline length in meter. R 为基线距离, 单位为米
	Roll or Pitch Accuracy (dual-board) 横滚或俯仰角 (双板卡)	(0.4/R)°, R is baseline length in meter. R 为基线距离, 单位为米
RTD Performance RTD 性能	Pseudorange Differential Accuracy(1σ) 伪距差分精度(1σ)	H: ± 0.25 m V: ± 0.5 m
RTK	RTK Initiation time RTK 初始化时间	< 10s (baseline<20km, 基线长小于 20km)

K706 SPECIFICATION/ K706 规范		
	Initiation Reliability 初始化置信度	> 99.9%
	RTK Accuracy RTK 精度	H: $\pm(10 + 0.5 \times 10^{-6} \times D)$ mm V: $\pm(20 + 0.5 \times 10^{-6} \times D)$ mm
	E-RTK ^{Note1} Initiation Time E-RTK 初始化时间	1s
	Initiation Reliability 初始化置信度	> 99.9%
	E-RTK Accuracy E-RTK 精度	H: $\pm(200 + 1 \times 10^{-6} \times D)$ mm V: $\pm(400 + 1 \times 10^{-6} \times D)$ mm
Data Rates 数据速率	Measurements & Position 测量&定位	1Hz, 2Hz, 5Hz, 10Hz, 20Hz, 50Hz (Max)
Electrical 电气特性	Data Storage Space 数据存储空间	8GB
	Voltage 供电电压	+3.3V ~ +5.5V \pm 5% DC
	Power Consumption 功耗	1.68 W
Environmental 环境要求	Operating Temperature 工作温度	-40°C — +80°C
	Storage Temperature 储存温度	-55°C — +95°C
Data Formats 输出数据格式	NMEA-0183	GPGLL, GPGGA, GPRMC, GPVTG, GPZDA etc.
	BINEX	0x00, 0x01-01, 0x01-02, 0x01-05, 0x7d-00, 0x7e-00, 0x7f-05
	ComNav Binary 司南二进制格式	ComNav Self-Defined 司南自定义

K706 SPECIFICATION/ K706 规范		
	CMR(GPS)	CMROBS, CMRREF
	RTCM2.X	RTCM1, RTCM3, RTCM9, RTCM1819, RTCM31, RTCM59
	RTCM3.0	1002, 1003, 1004, 1005, 1006, 1007, 1008, 1010, 1011, 1012, 1019, 1020, 1104, 1033
	RTCM3.2 MSM4/MSM5	1074, 1084, 1124,1075,1085,1125,1230
	Other	PTNL,PJK, PTNL,GGK, PTNL,AVR, NAVPOS
Antenna Interface 天线接口	Antenna Connector 天线连接器	MCX female (MCX 母头) 50Ω
	LNA Power 天线供电电压	External 外部供电: +5V ±2% DC @ 0-100mA
	LNA Gain 天线增益	20 ~ 45dB (suggested 建议)
Hardware Interface 硬件接口		2×12 pin male connector, pin pitch 2mm 24 针公头, 针脚间距 2mm
Physical 物理参数	Size 尺寸	45.7mm×71.1mm×9.6mm with connectors (含接头)
	Weight 重量	26.6 gram 克

Note1: Super wide lane solution 超宽巷解

III. DIMENSION / 尺寸

In this section, three-side views and the dimension of K706 are provided for customers' further hardware design and installation.

本节提供了 K706 的三视图和对应的物理尺寸，便于用户的进一步系统硬件设计和安装。

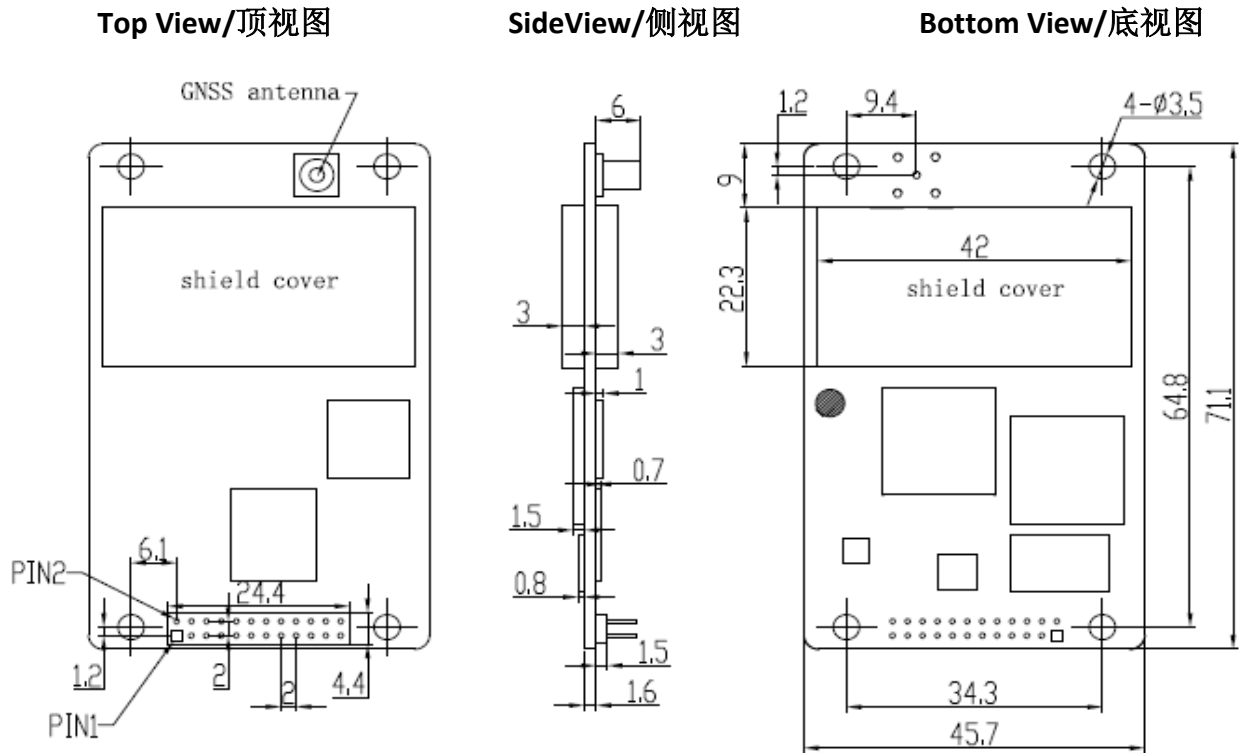

Figure 1. K706 Dimension View

图 1. K706 三视图

TIPS 提示:

The copy of AutoCAD dwg files as shown in figure 1 can be obtained from the attachment of this document, which can be imported into EDA tools directly facilitating your system hardware design.

该文档的附件包含上面的 AutoCAD dwg 文件，可直接导入 EDA 软件用于系统硬件设计。

IV. PIN ARRANGEMENT AND DEFINITION / 引脚标识和定义

K706 has one 24-Pin connector (12 Pin, 2mm Dual Row vertical T/H HDR).

K706 板卡包括 24 针接头（针脚间距 2mm，双排）。

Table 2. Pin Definition of K706 24-Pin Connector

PIN	SIGNAL	TYPE	DESCRIPTION
1	SPI_CLK / ETH_RD-	MUL	multiplexed pin: SPI clock signal / 复用管脚: SPI 总线时钟信号/ Ethernet receive signal (-) 以太网接收信号 (-)

©2017, ComNav Technology Ltd. All rights reserved. SinoGNSS is the trade mark of ComNav Technology Ltd., registered in People's Republic of China. All other trademarks are the property of their respective owners.

PIN	SIGNAL	TYPE	DESCRIPTION
			default: ETH_RD- 默认: ETH_RD-
2	SPI_CS0 / ETH_RD+	MUL	<p>multiplexed pin: SPI1 CS0 signal / 复用管脚: SPI 总线片选信号/ Ethernet receive signal (+) 以太网接收信号 (+) default: ETH_RD+ 默认: ETH_RD+</p>
3	LNA_PWR	PWR	antenna power supply 天线供电
4	3V3	PWR	DC power supply for board 板卡供电电源
5	USB_N	IO	USB device interface data (-) USB 数据信号 (+)
6	USBP / COM3_RX	MUL	<p>multiplexed pin: USB device 复用管脚: USB 数据信号 (+) interface data (+) / UART /COM3 串口输入 received data for COM3 input 默认: USBP default: USBP</p>
7	RST_SYS	I	system reset 系统复位
8	VARF / CAN1_RX	MUL	<p>multiplexed pin: 10MHz square 复用管脚: 10MHz 方波输出 wave output / CAN1 input /CAN1 数据接收信号 default: CAN1_RX 默认: CAN1_RX</p>
9	EVENT2 / CAN1_TX	MUL	<p>multiplexed pin: external event 复用管脚: 外部事件 2 输入 input / CAN1 output /CAN1 数据发送信号 default: EVENT2 默认: EVENT2</p>
10	CAN2_RX / LED_RTK	MUL	<p>multiplexed pin: CAN2 input / 复用管脚: CAN2 数据接收/RTK RTK data LED indicator 数据指示灯 Default: LED_RTK 默认: LED_RTK</p>
11	EVENT1 / COM3_TX	MUL	<p>multiplexed pin: external event 复用管脚: 外部事件 1 输入 input / UART transmitted data for /COM3 串口输出 COM3 默认: EVENT1 default: EVENT1</p>
12	GND	PWR	ground reference 系统接地
13	COM1_TX	O	transmitted data for COM1 COM1 串口输出

©2017, ComNav Technology Ltd. All rights reserved. SinoGNSS is the trade mark of ComNav Technology Ltd., registered in People's Republic of China. All other trademarks are the property of their respective owners.

PIN	SIGNAL	TYPE	DESCRIPTION
			output
14	COM1_RX	I	received data for COM1 input COM1 串口输入
15	GND	PWR	ground reference 系统接地
16	COM2_TX	O	transmitted data for COM2 output COM2 串口输出
17	COM2_RX	I	received data for COM2 input COM2 串口输入
18	GND	PWR	ground reference 系统接地
19	PV	O	'good solution' or valid GPS position indicator 位置有效指示信号
20	GND	PWR	ground reference 系统接地
21	PPS	O	pulse per second 秒脉冲
22	CAN2_TX / LED_SAT	MUL	multiplexed pin: CAN2 output / tracked satellite number indicator default: LED_SAT 复用管脚: CAN2 数据接收信号 /跟踪卫星数量指示灯 默认: LED_SAT
23	SPI_MISO / ETH_TD+	MUL	multiplexed pin: SPI master in slave out signal / Ethernet transmit signal (+) Default: ETH_TD+ 复用管脚: SPI 主输入从输出信 号/以太网传输信号 (+) 默认: ETH_TD+
24	SPI_MOSI / ETH_TD-	MUL	multiplexed pin: SPI1 master out slave in signal / Ethernet transmit signal (-) default: ETH_TD- 复用管脚: SPI 主输出从输入信 号/以太网传输信号 (-) 默认: ETH_TD-

REMARKS / 说明:

- CAN are not available now.

CAN目前不可用。

2. Electronic characteristic/电气特性

RTK_LED, SAT_LED, COM1_Tx, COM1_Rx, COM2_Tx, COM2_Rx, COM3_Tx, COM3_Rx, CAN1_RX, CAN1_TX, CAN2_TX, CAN2_RX, RESETIN, SPI_CLK, SPI_CS, SPI_MOSI and SPI_MISO are LVCMOS 3.3V.

RTK_LED、SAT_LED、COM1_Tx、COM1_Rx、COM2_Tx、COM2_Rx、COM3_Tx、COM3_Rx、CAN1_RX、CAN1_TX、CAN2_TX、CAN2_RX、RESETIN、SPI_CLK、SPI_CS、SPI_MOSI以及SPI_MISO为LVCMOS 3.3V电气标准。

LVCMOS 3.3V电气标准

Symbols 符号	Description 描述	Min 最小	Max 最大
V _{IH}	Input high voltage 输入高电压	2V	3.6V
V _{IL}	Input low voltage 输入低电压	-0.3V	0.8V
V _{OH}	High-level output voltage 高电平输出电压	2.9V	--
V _{OL}	Low-level output voltage 低电平输出电压	--	0.4V
I _{OH}	Sourcing current 拉电流	8mA	
I _{OL}	Sinking current 灌电流	8mA	

3. PPS, EVENT, EVENT2 and VARF are LVTTTL3.3V. All these signals are compatible with LVCMOS/LVTTTL 3.3V.

PPS、EVENT、EVENT2和VARF为LVTTTL3.3 V电平，所有这些信号均兼容LVCMOS/LVTTTL 3.3V。

Symbols/符号	Description/描述	Min/最小	Max/最大
V _{IH}	Input high voltage 输入高电压	2.0V	---
V _{IL}	Input low voltage 输入低电压	-0.3V	0.8V
V _{OH}	High-level output voltage 高电平输出电压	2.4V	---
V _{OL}	Low-level output voltage 低电平输出电压	---	0.4V
I _{OH}	Sourcing current 拉电流	8mA	
I _{OL}	Sinking current 灌电流	8mA	

4. Absolute maximum rating is -0.3V ~ 3.6V of following signals:

©2017, ComNav Technology Ltd. All rights reserved. SinoGNSS is the trade mark of ComNav Technology Ltd., registered in People's Republic of China. All other trademarks are the property of their respective owners.

所能承受电压的最大值范围是-0.3V ~ 3.6V的信号如下：

RTK_LED, SAT_LED, COM1_Rx, COM1_Tx, COM2_Rx, COM2_Tx, COM3_Rx, COM3_Tx, EVENT, EVENT2, PPS, VARF, RESETIN, CAN1_Rx, CAN1_Tx, CAN2_Rx, CAN2_Tx, SPI_CLK, SPI_CS, PI_MOSI, SPI_MISO.

5. CAN is LVTTTL 3.3V, so a transceiver is needed for normal use.

CAN是LVTTTL 3.3V，所以需要有一个收发器才能正常使用。

6. USB

K706 USB has a built-in controller. The unit supports USB 2.0 Device configuration at low/full/high speed configuration. The port has ESD protection, but a USB 2.0 compliant common mode choke should be added near the USB connector if better EMI performance is needed.

VBUS is only used for USB cable plug-in detection as an input IO. You can connect VBUS directly to USB connector.

K706使用内建控制器，可配置为低速/全速/高速USB设备。接口有做ESD防护，如果需要获得较好的EMC表现，可以在接插件处增加安装共模电感。

VBUS用作USB线缆接入检测，直接将VBUS引脚连接到USB接插件的VBUS引脚。

7. ETHERNET

LAN8720 is used by K706 as a network transceiver, with 10M/100M Ethernet communication function and the default setting is 100M full-duplex communications. It also has auto-negotiation function. OEM board does not have any internal magnetics and ESD protection. Additional magnetics and TVS diode are required to ensure a stable and secure Ethernet network communication. Ethernet default off.

K706 使用LAN8720作为网络收发器，具备10M/100M以太网通讯功能，默认设置为100M全双工通讯，具备自动诊断及自适应线缆功能。OEM板卡内部不包含网络变压器以及ESD保护措施，需要额外的网络变压器以及TVS二极管确保稳定安全的以太网网络通讯。网络功能系统默认关闭。

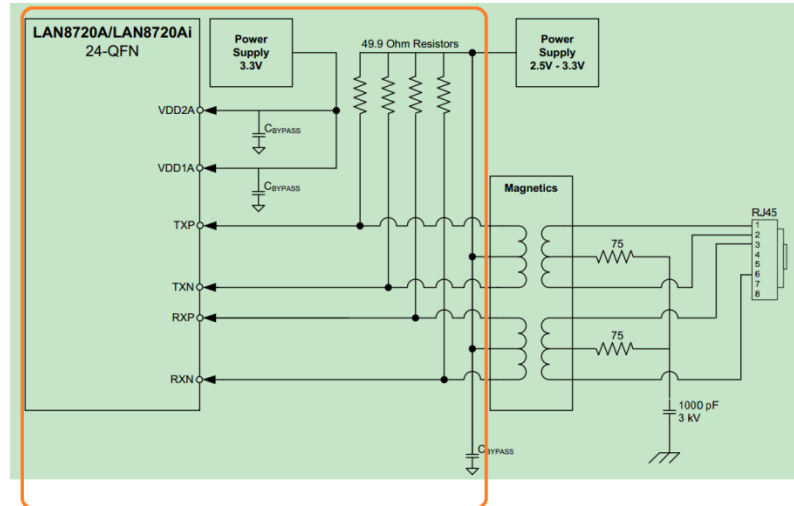

Figure 2. LAN8720 Connection Diagram

图2. LAN8720连接框图

8. VCC

It is main power supply, which voltage range is 3.3VDC ~ 5.5V DC.

The requirement for voltage ripple and spike is less than 100mV.

主供电电源，电压范围：3.3V ~ 5.5V（直流）。电压纹波和尖峰脉冲要求小于100mV。

9. SYS_RST

It is low active and can be used to reset the whole OEM board. It is 3.0V compatible.

低电平有效，可用于复位整个OEM板。

10. RTK_LED / SAT_LED

SAT_LED is used to indicate the satellite number. RTK_LED indicates that RTK is undergoing. Both RTK_LED and SAT_LED are all high active. External LED driver is needed for normal use.

RTK_LED闪烁指示接收到基准站的数据，SAT_LED指示卫星数量，一次连续闪烁的次数表示当前搜到卫星的数量。RTK_LED与SAT_LED均为高电平驱动LED，需要外加LED驱动。

V. APPLICATION CONNECTION EXAMPLE / 应用连接示例

In this section, an application connection example of K706 OEM board is presented via specific schematic diagrams. Per the instruction of these diagrams, you could easily build the

communication circuits between K706 OEM board and other terminals such as PC, GPRS or Bluetooth module, and some other devices with an UART.

本部分以具体电路的形式提供一个 K706 板卡应用连接示例。参照下面的图示，您可以很方便建立 K706 板卡和其他终端（如 PC，GPRS 模块，蓝牙模块或其他带有 UART 的设备）之间的通讯电路。

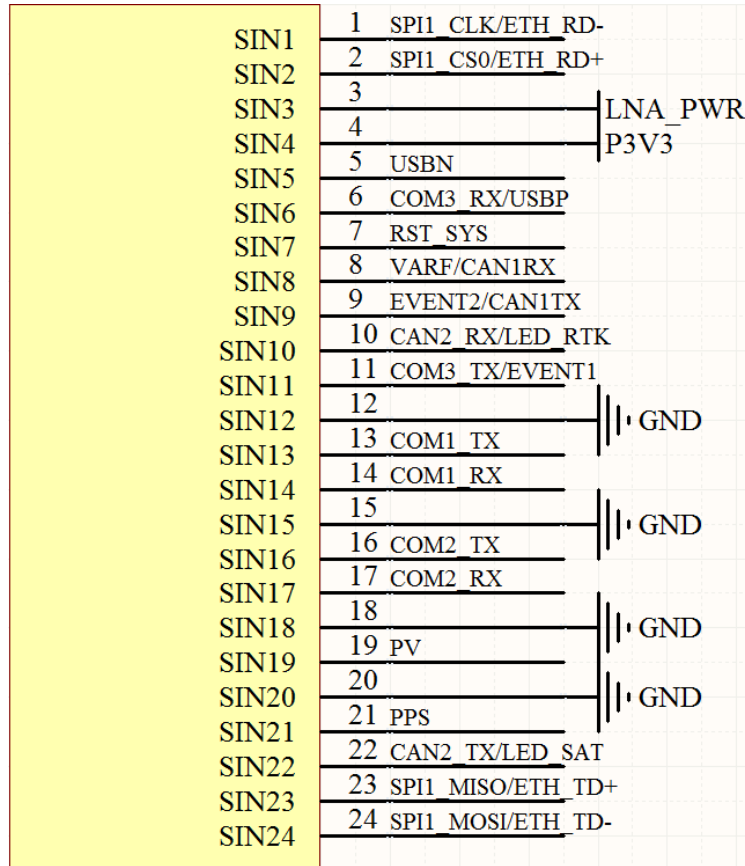

Figure 3. K706 Pin Assignment Schematic

图 3. K7006 引脚分配及外接电路示意

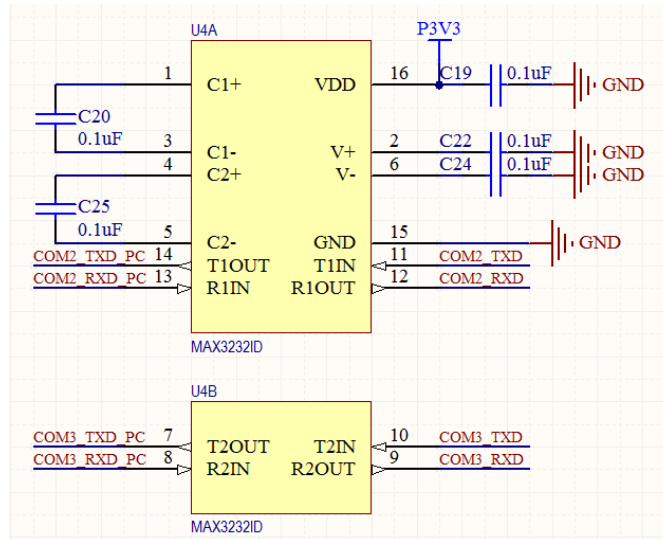

Figure 4. Connections between RS232 COM1, 2, 3 of K706 and Some Other Devices with an UART

图 4. K706 RS232 COM1/2/3 与其他使用 UART 接口的设备之间的连接示意

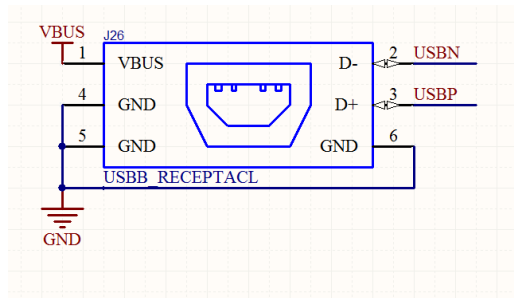

Figure 5. USB Connection

图 5. USB 连接

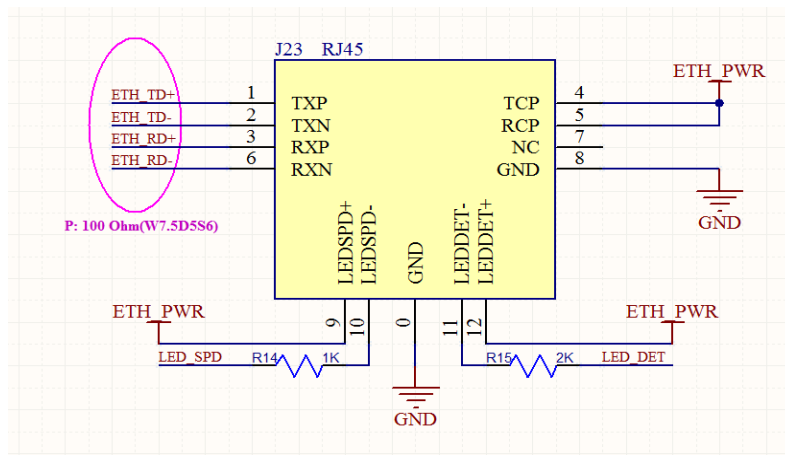

Figure 6. Network Connection

图 6. 网络连接

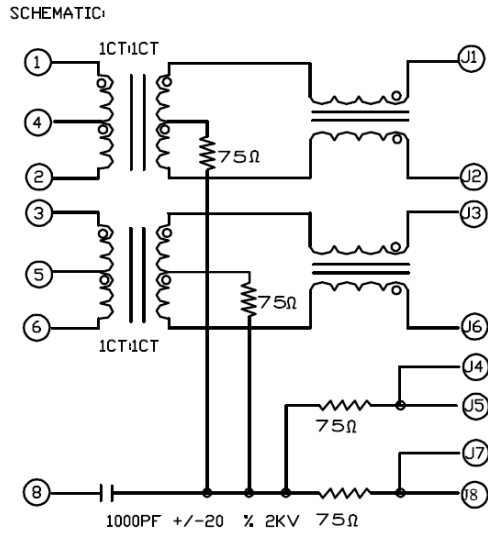

Figure 7. RJ45 Schematic

图 7. RJ45 原理图